

This technical note outlines a simple method to optimize the pulse response to the LDP-3840B pulsed laser driver by “tuning” to the specifics of your particular setup using the ILX Lightwave LPB series adapter kits.

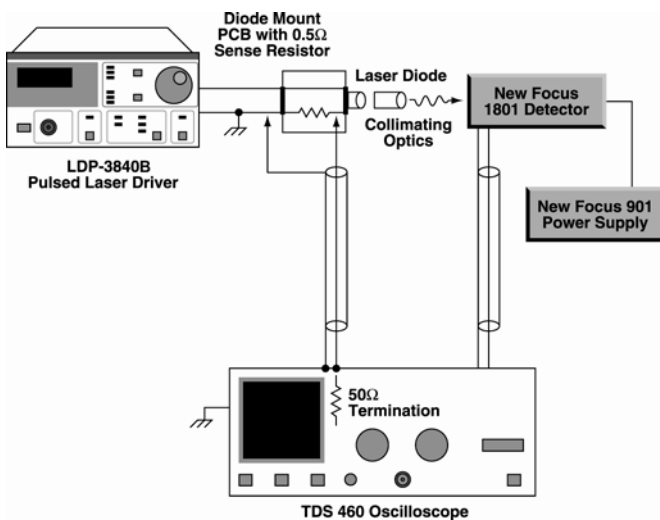

FIGURE 1 – Measurement Setup

### OVERVIEW

When dealing with pulse waveforms with rise times faster than 100 ns, unwanted parasitic effects can distort the pulse response. For example, laser package styles and mounting configurations can add significant reactance to the electrical path.

To cancel the effect of these application dependent parasitics, the LDP-3840B laser mounting boards allow for the addition of a small series resistance near the laser, as well as voltage and current monitor connections. The user can add resistance to compensate for any parasitic effects, and minimize ringing on the pulse.

### TUNING RESISTOR SELECTION

The added “tuning” resistance has an impact on the rise time of the pulse, so it must be chosen carefully. The optimum resistance value will depend on the specific test setup. Fortunately, the method for selecting the value of resistance is relatively straightforward. The procedure is as follows:

1. Minimize the reactive impedance in your test setup. The laser should be mounted with the shortest leads that can be used and still allow for mechanical mounting. This will reduce stray inductance and capacitance.

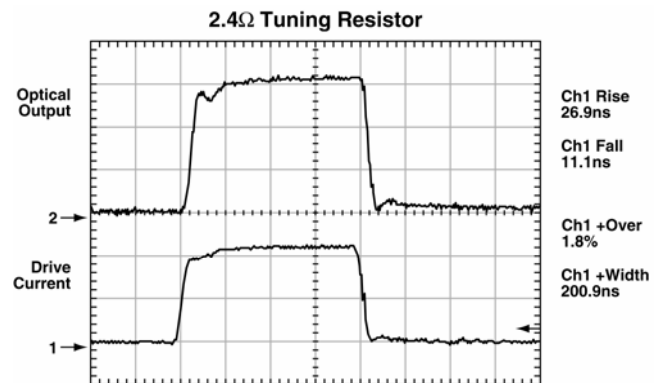

FIGURE 2 – Pulse Response with 2.4 Ω

2. Characterize the pulse response using the supplied PCB, which is preloaded 0.5 Ω for tuning. In our example, pulses were measured with a laser in a non-temperature controlled mount, as shown in Figure 1, and optically measured with a New Focus 1801 high speed detector.
3. Reduce the series resistance (by adding resistors in parallel). This will reduce the dampening of the pulse response in increase both rise time and overshoot. Increasing the

# TECH NOTE

resistance (by removing the resistors) will have the opposite effect. Continue to decrease the resistance until the desired balance between rise time and overshoot is acceptable for your application. (Figures 3 and 4).

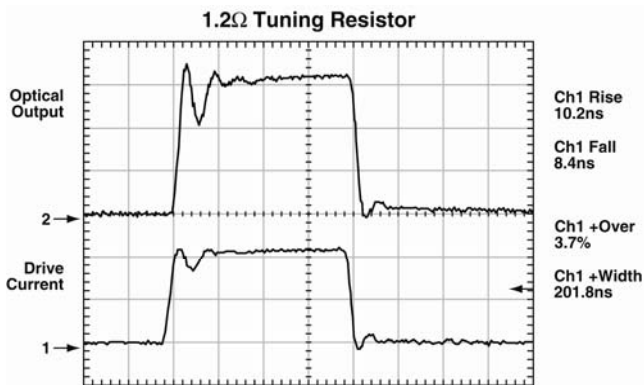

FIGURE 3 – Pulse response with 1.2 Ω

In many cases, this step can be omitted if the waveform at 0.5 Ω is adequate. The pulse response of our setup using a 2.4 Ω resistance is illustrated in Figure 2.

Using this method, the optimum resistance value can be determined in 2 or 3 iterations. The effect of the decreased series resistance can be easily seen in Figures 2 through 4. Notice that as the rise time is reduced, the overshoot and settling time (which are often the criteria of interest) increase rapidly. For the example test setup, a resistance value of around 2 Ω was appropriate.

## VOLTAGE AND CURRENT MONITOR CONNECTIONS

The laser mounting board provides the ability to measure laser voltage and current with great accuracy using 50 Ω terminated oscilloscope connections. The current monitor is especially useful for gathering data for accurate

characterization of light versus current using high speed pulses. The voltage across the 0.5 Ω sense resistor is precisely proportional to laser current. The cable model LPC-388 is available to connect from the SMB connector to a BNC input on an oscilloscope.

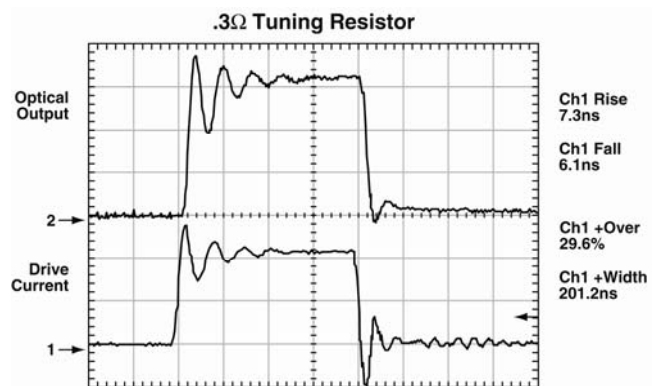

FIGURE 4 – Pulse response with 0.3 Ω

Note in Figure 5 that the voltage monitor connection forms a conducting path in parallel with the laser. The calibration of the LDP-3840B is performed with this connection in place, and for greatest accuracy, this connection must be terminated in 50 Ω. This also provides for a low impedance when the laser is turning off. If the user chooses to make a custom circuit, it is highly recommended to include this resistive path. SMB style 50 Ω terminators are provided with the LPB-380 for users that do not need to use the monitor connections.

For further information on the transmission line effects in driving a laser diode, see ILX Application Note #11, “Pulsing a Laser Diode”.

# TECH NOTE

## LASER MOUNTING BOARD ACCESSORIES

LPB-380	Laser Mounting Board
LPC-388	C/V Monitor Cable
CC-380	Output Cable
FTT-389	50 Ω BNC Terminator

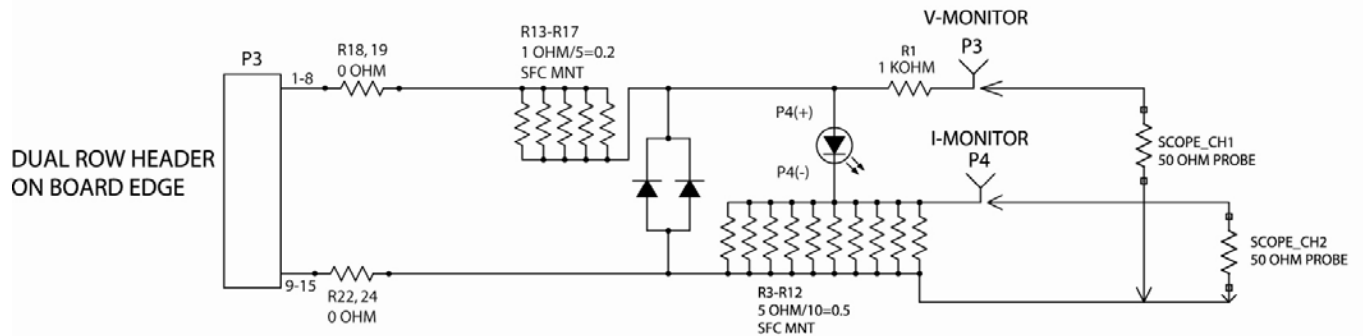

FIGURE 5 – Laser Mounting Board Schematic Configured Case Positive