

Using Three-Wire RTDs with the LDT-5900 Series Temperature Controllers

PURPOSE

This Technical Note presents the proper method for using three-wire RTD sensors with the ILX Lightwave LDT-5900 Series temperature controllers.

BACKGROUND

Three-wire RTD temperature sensors are commonly used in applications where the RTD is located a substantial distance from the temperature controller. Three-wire RTDs can be configured so that the resistance from the long leads is effectively cancelled, but a specialized measurement system is required. Figure 1 shows a typical three-wire RTD measurement system.

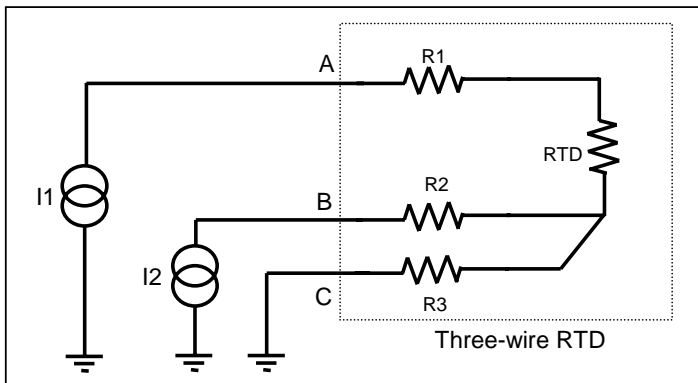

Figure 1 Three-Wire RTD System

Two matched current sources are required for this application, I_1 and I_2 . To measure the actual voltage drop across the RTD, I_1 is switched on and the voltage between points A and C is measured, (V_{AC}). Next, I_1 is switched off and I_2 is switched on; the voltage between points B and C is measured, (V_{BC}). Assuming that $R_1 = R_2 = R_3$, subtracting the V_{BC} from V_{AC} gives the voltage drop across the RTD and effectively cancels the lead wire resistances, R_1 , R_2 , and R_3 .

$$V_{AC} = V_{R1} + V_{RTD} + V_{R3}$$

$$V_{BC} = V_{R2} + V_{R3}$$

$$V_{RTD} = V_{AC} - V_{BC}$$

$$= V_{R1} + V_{RTD} + V_{R3} - V_{R2} - V_{R3}; \text{ Assume } V_{R1} = V_{R2} = V_{R3}$$

$$= V_{R1} + V_{RTD} + V_{R3} - V_{R1} - V_{R3}$$

Once V_{RTD} is known, it is a simple matter to calculate R_{RTD} using the RTD excitation current I_1 and Ohm's Law. This method is conceptually simple, but difficult to execute in practice because the two current sources must be precisely matched.

The LDT-5900 Series temperature controllers have four-wire sensor measurement systems, and so a two- or four-wire RTD is the most logical RTD to use. Some lab equipment is designed with an integrated three-wire RTD, and there is no easy way to replace it with a four-wire type. In these cases, following the method described in this document will result in the lowest possible measurement error.

MEASUREMENT SETUP

Figure 2 illustrates the recommended wiring connection configuration for three-wire RTD sensors. This method takes advantage of the LDT-5900 Series four-wire voltage sensing capability to reduce the error caused by the RTD lead-wire resistance.

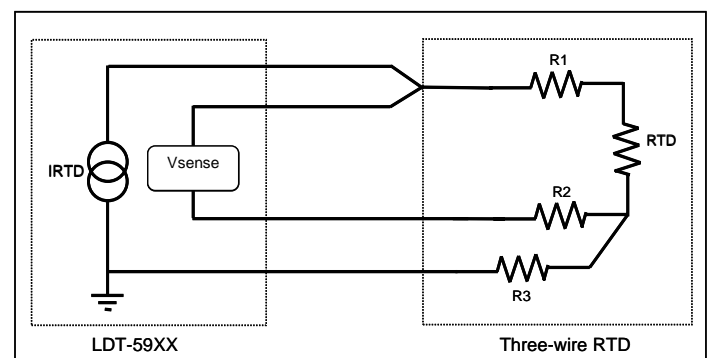

Figure 2 Recommended 3-Wire Configuration



Using Three-Wire RTDs with the LDT-5900 Series Temperature Controllers *continued*

Because of the four-wire voltage sense geometry, the voltage across lead resistances R2 and R3 are not measured. The only error induced the measurement is R1, and if the leads are kept short then this resistance is negligible.

In these applications, it is critical to keep the lead wires from the RTD as short as possible to reduce the resistance contribution. Table 1 presents some examples of potential error caused by 1 foot long RTD leads with different gauge wires.

RESULTS

ILX Lightwave recommends using a four-wire RTD whenever possible, but the LDT-5900 Series temperature controllers can be used with three-wire RTDs as long as the lead wires are cut as short as possible. Lead wires as long as 1 foot may induce a temperature measurement error of up to 0.12% at 25°C.

Table 1
Error Induced by 1 Foot RTD Leads at 25°C

	30 ga	24 ga	22 ga	20 ga
R_1 (Ω /foot)	0.1330	0.0333	0.0213	0.0148
R_{RTD}	109.875	109.875	109.875	109.875
$R_{RTD} + R_1$	110.008	109.908	109.896	109.89
Error	0.12%	0.03%	0.02%	0.01%

Notice that smaller diameter lead wire (higher gauge number) will induce greater errors because they are more resistive than larger diameter lead wires.