

PURPOSE

This technical note discusses the thermal resistance between a C-mount laser diode and the LDM-4409 Laser Diode Mounting Fixture. The tests were performed on a production mounting fixture with a customized C-mount laser in a laboratory environment with test equipment configured as illustrated in Figure 1. Test Setup.

INTRODUCTION

Contact thermal resistance is a result of surface imperfections between two mating surfaces and characterized by a temperature difference between the two surfaces under a given heat load. It is quantified in °C/W and is related to the surface finish, clamping force and materials used for the mating surfaces. Thermal resistance between a laser diode and a mating surface becomes an issue with high power laser diodes for the simple reason that the higher heat loads lead directly to an increase in temperature of the laser.

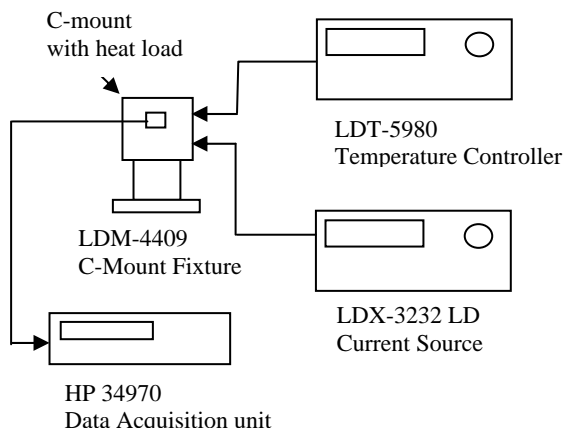

FIGURE 1 – Test Setup

MEASUREMENT SETUP

A C-mount laser was modified by attaching a thermo-couple to measure the temperature rise of the laser. A power resistor was then soldered to the C-mount package which, when energized, provided a known heat load. An ILX LDX-3232 4A Current Source was used to provide current to and measure the voltage across the diode. An ILX LDT-5980 Precision Temperature Controller was used to control the 4409's hot plate temperature. An HP-34970 Data Acquisition Unit was used to measure the temperature of the C-mount laser.

To start the test, the temperature of the modified C-mount was recorded without any heat load. Then, current was applied to the power resistor and both the current and voltage across the resistor was recorded. With the heat load applied, the resulting temperature of the C-mount was recorded. Thermal resistance was then calculated by dividing the temperature change of the modified C-mount by the input power. Tests were run with the hot plate at 10°C, 20°C and 85°C with the C-mount clamped with the LDM-4409 spring clamp only. The same tests were repeated with the C-mount fastened to the hot plate with a #2-56 screw torqued to 3 in-lbs.

RESULTS

With the modified C-mount held down with the spring clamp only and a 0.92W heat load to the mounting fixture, a device temperature rise of 2.3°C was observed. This corresponds to a thermal resistance of 2.5°C/W.

With the modified C-mount held down with a #2-56 screw torqued to 3 in-lbs and a 0.92W heat load to the mounting fixture, a device temperature rise of

0.6°C was observed. This corresponds to a thermal resistance of 0.65°C/W.

Additional testing was done to determine the optimal torque for the mounting screw. The change in thermal resistance is inversely proportional to torque i.e., the higher the torque, the lower the thermal resistance. As shown in Figure 2, with no torque on the mounting screw, a thermal resistance of approximately 2.4°C/W was measured. As torque increased, the thermal resistance decreased rapidly. However past approximately 1 in-lb, increased torque leads to little change in thermal resistance.

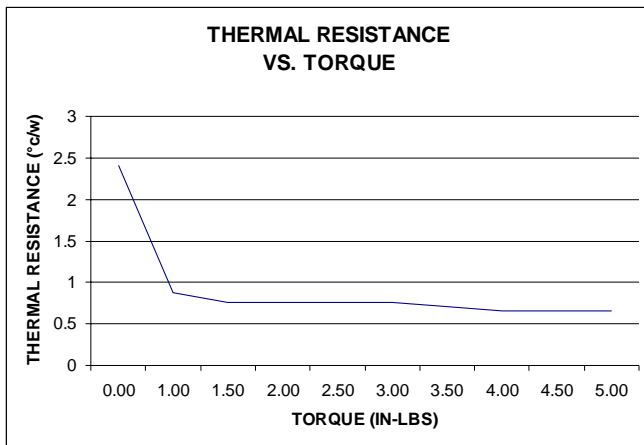

FIGURE 2 – Thermal Resistance vs. Torque

The thermal resistance repeatability of the system was measured as well. The device was removed and inserted 8 times with the thermal resistance measured at each insertion. This test was completed for the device held by the spring clamp only, and with the device held with the spring clamp and the #2-56 screw.

The standard deviation of the thermal resistance with the device held by the spring clamp only was 0.2°C/W. The standard deviation of the thermal resistance with the device held with the screw torqued to 3 in-lbs was 0.06°C/W.

In summary, the performance and optical measurements of a C-mount laser diode are dependent on the performance of the mounting fixture especially with respect to the thermal resistance between the device and the mount. Increased thermal resistance can lead to relatively large differences in temperature between the fixture and the C-mount. Because laser diode properties such as threshold, efficiency, and wavelength are affected by temperature, and because of the high optical power of C-mount devices, it is important to know and ultimately account for, thermal performance characteristics of the mounting fixture.

The LDM-4409 C-Mount Fixture is a convenient tool for mounting and measuring optical properties of C-mount devices. It was designed to reduce the thermal resistance between the C-mount and the fixture. Thermal resistance depends on the quality of the mating surfaces, the force on the C-mount laser, and the thermal load. The temperature rise of the laser can be minimized with the proper torque on the mounting screw and with care for the mounting surface to keep it clean and free of scratches.