

# LDX-3232 Modulation Bandwidth

## INTRODUCTION

This Tech Note provides information on the modulation bandwidth of the LDX-3232 High Compliance Laser Diode Driver. The output of the LDX-3232 is capable of being modulated via a signal input into the front panel BNC labeled External Modulation. This feature is designed to allow output current modulation through the summing of a continuously varying signal with the CW bias current. The magnitude of the additional current is proportional to the modulation voltage and the proportionality constant is called the modulation transfer function. For the LDX-3232, this transfer function is 200 mA/V in the 2 Amp range and 400 mA/V in the 4 Amp output range.

The total output current may be easily determined when one remembers it is the CW bias current plus modulation current. For example, if the CW bias is set to 1000 mA with no modulation input, the output will obviously be 1000 mA. Now, if a sinusoidally varying voltage with a maximum of 1.0 V and a minimum of 0.0 V is input via the modulation BNC, the output current will vary from a maximum of 1200 mA [1000 mA + (200 mA/V) x (1.0 V max)] to a minimum of 1000 mA if the instrument is in the low output range. Because of the input impedance of the modulation circuit (1 kΩ in the case of the 3232), it is advisable to connect the function generator to the instrument with the instrument's output disabled so the modulation voltage and therefore modulated current may be more accurately set.

## TEST SETUP

The test setup consisted of an LDX-3232 connected to a butterfly-packaged laser diode attached to an ILX Lightwave LDM-4984 laser mount. Control of the laser's internal Peltier was accomplished using an LDT-5948. The output of an Agilent 33120A function generator provided the modulation signal to the 3232 and a Tektronix TDS3014 oscilloscope. The fiber-coupled laser output was fed through a JDS Fitel HA1 Optical Attenuator to attenuate the output so the ThorLabs PDA400 photodetector used to measure the modulated output would not become saturated. The PDA400 output was connected to one channel of the TDS3014 so it could be compared against the input modulation signal on the second scope channel. The PDA400 has adjustable amplification and therefore, adjustable bandwidth.

To roughly match that of the LDX-3232, the 20 dB gain setting was selected to provide a bandwidth of 700 kHz.

Four tests were run to determine modulation bandwidth. Two were run with the LDX-3232 set in CW (low bandwidth) mode and two in High Bandwidth mode. In each mode a test was run where the maximum output current was 200 mA and was either 100% or 50%-modulated. In the former test, CW bias current (low output range) was set to zero and the input modulation signal set to 1 Vpp with an offset of 0.5 V. The latter test was configured for 100 mA of CW bias current with an input modulation signal of 0.5 Vpp and an offset of 0.25 V. The modulation signal was in the form of a sine wave whose frequency was varied up to (and in some cases beyond) the instrument's maximum specified bandwidth of 10 kHz in CW (low bandwidth) mode and 250 kHz in high bandwidth mode. The test setup is shown schematically in Figure 1.

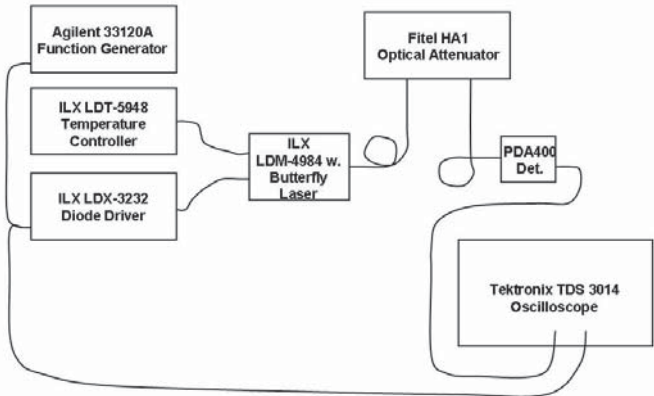

Figure 1: Test Setup

## TEST RESULTS

The modulation frequency was scanned from 1 Hz to 50 kHz while in CW (low bandwidth) output mode, from 1 Hz to 250 kHz while in high bandwidth mode, 100% modulation, and from 1 Hz to 1 MHz while in high bandwidth mode, 50% modulation. Figures 2 through 5 show the resultant frequency performance. Figure 2 depicts low bandwidth frequency response with 50% and 100% modulation. Slightly less attenuation at frequencies



# LDX-3232 Modulation Bandwidth

higher than 30 kHz can be seen when the modulation is reduced to 50%. This is understandable because the modulation circuitry does not have to swing the output from zero to 200 mA as is required for 100% modulation.

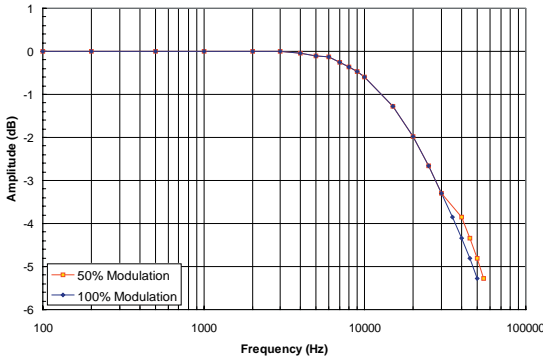

Figure 2: Low BW Modulation

Figure 3 shows the high bandwidth performance differences between 50% and 100% modulation. In this case, the effect is substantial. In fact, the instrument will not allow 100% sinewave modulation at 250 kHz, even over this small range of current. If attempted, the instrument's laser protection circuitry will shut the output off with an open circuit error.

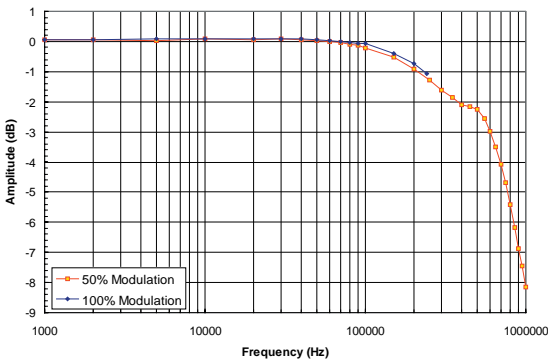

Figure 3: High BW Modulation

One of the laser diode protection circuits designed into each driver produced by ILX Lightwave will quickly shut the output off if an open circuit condition is detected. In an open circuit, the compliance voltage quickly rises in an attempt to force current to

flow. If the circuit is suddenly completed in this state, the laser will experience this overvoltage condition and could potentially be damaged. To prevent this, the instrument's protection circuitry will shut the output off. Figures 4 & 5 show the input modulation signal (red) and laser output (blue) when modulated at 50% in high bandwidth mode at 1 kHz and 1 MHz. Note there is a small phase shift in the output at the higher frequencies.

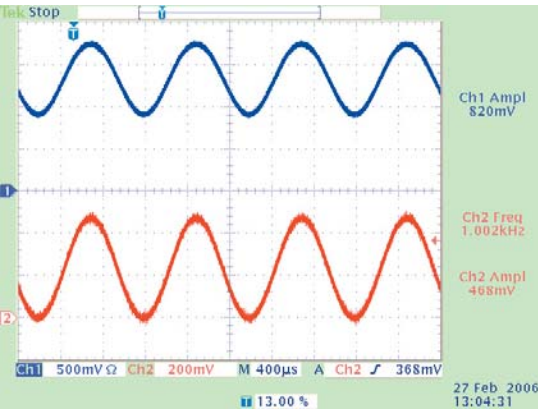

Figure 4: High BW Modulation @ 1 kHz

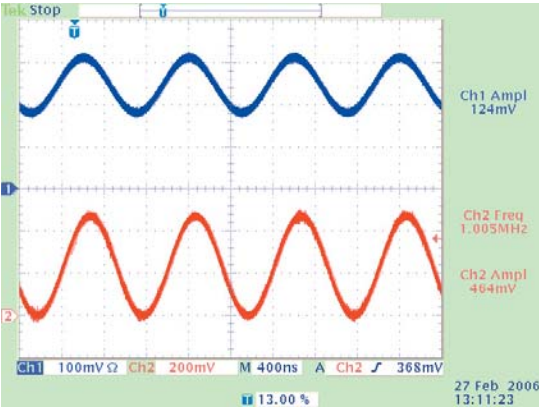

Figure 5: High BW Modulation @ 1 MHz

## CONCLUSION

In summary, the usable bandwidth of the LDX-3232 can extend beyond the 10 kHz and 250 kHz limits called out in the instrument's specifications. The actual bandwidth obtained depends heavily on the magnitude and type of modulation required.