

# Four-Wire TEC Voltage Measurement with the LDT-5900 Series Temperature Controllers

## PURPOSE

This Technical Note presents data showing the important difference between 2-wire and 4-wire TEC voltage sensing with the ILX Lightwave LDT-5900 Series temperature controllers.

## BACKGROUND

Four-wire voltage sensing is necessary in high-current and high-precision temperature control applications where the accuracy of the TEC measurements is critical. In this technical note, results from the four-wire cable characterization are presented, and differences between two-wire and four-wire measurements highlighted.

In a four-wire measurement system, separate wires are used for current supply and voltage measurement. The current supply wires have a resistance, and so there is a voltage drop across those wires. The voltage sense wires do not carry any current, so there is essentially no voltage drop across them. This fact makes four-wire sensing inherently more accurate than two-wire sensing, where the same two wires are used for current supply and voltage sensing.

## MEASUREMENT SETUP

A 1Ω, 50 W power resistor was connected to the LDT-5980 Temperature Controller using the standard high-current interconnect cable. Separate digital voltmeters (DVM) were used to monitor the voltage at the instrument back panel and at the load. The setup is shown in Figure 1.

The drive current was stepped from 1.0 A to 7.0 A and the voltages recorded. The DVM at the instrument back panel simulates a two-wire voltage measurement since the leads are connected to the TEC current supply wires, and therefore measure the voltage drop across the cable in addition to the voltage drop across the load. The DVM at the 1Ω load simulates a 4-wire measurement since the voltage drop across the current supply wires is not measured.

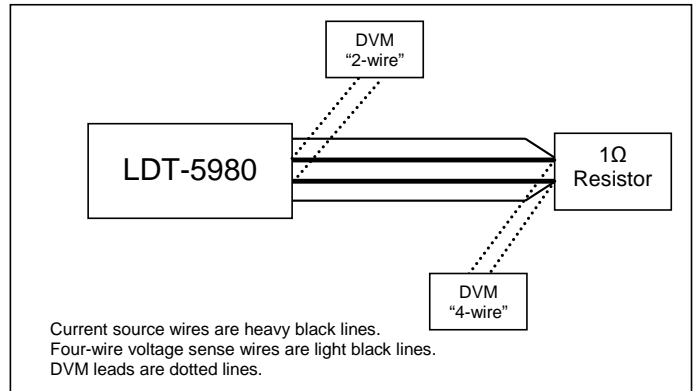

Figure 1 Experiment Setup

## RESULTS

Table 1 shows the data from the multimeters and the LDT-5980. Subtracting the LDT-5980 four-wire voltage measurement from the load voltage gives the cable voltage drop, which also equals the difference between four-wire and two-wire voltage measurements.

Table 1  
Experiment Results

| Drive Current (A) | Four-Wire Voltage (V, LDT-5900) | DVM "4-Wire" (V, voltmeter) | DVM "2-Wire" (V, voltmeter) | Cable Voltage Drop (V) |
|-------------------|---------------------------------|-----------------------------|-----------------------------|------------------------|
| 1.000             | 1.000                           | 0.992                       | 1.045                       | 0.053                  |
| 2.035             | 2.035                           | 2.003                       | 2.110                       | 0.107                  |
| 2.989             | 3.010                           | 2.983                       | 3.143                       | 0.160                  |
| 4.010             | 4.029                           | 4.008                       | 4.224                       | 0.216                  |
| 5.012             | 5.051                           | 5.018                       | 5.290                       | 0.272                  |
| 6.005             | 6.039                           | 6.006                       | 6.332                       | 0.326                  |
| 7.020             | 7.059                           | 7.019                       | 7.403                       | 0.384                  |



# Using Three-Wire RTDs with the LDT-5900 Series Temperature Controllers *continued*

The error between two-wire and four-wire measurements is approximately 5%. This error can be critical when characterizing TECs in final test, where the specification window for module power consumption may be narrower than 5%.

Table 2 presents some additional interesting information on resistance and power dissipation in the cable. Ohm's Law can be used to calculate the resistance of the current source wires by dividing the voltage drop by the drive current.

$$R = V / I = 0.107 / 2.035 = 53 \text{ m}\Omega$$

The cable power dissipation can be calculated by multiplying the voltage drop by the current.

$$P = V * I = 0.384 * 7.020 = 2.696 \text{ W}$$

### CONCLUSION

The 5% error between four-wire and two-wire measurements can have a large impact on device characterization, including total module power consumption and  $R_{AC}$  measurements.

For example, the LDT-5980 measures AC resistance by driving a  $\pm 50$  mA square wave and measuring the voltage drop across the TEC. If the LDT-5980 used only two-wire voltage sense the AC resistance measurement uncertainty would be approximately 5%. By implementing four-wire voltage sensing, we are able to guarantee an  $R_{AC}$  accuracy of 1%.

**Table 2**

**Cable Voltage Drop and Power Dissipation Data**

| Drive Current (A) | Cable Voltage Drop (V) | Cable Resistance( $\Omega$ ) | Cable Power Dissipation (W) |
|-------------------|------------------------|------------------------------|-----------------------------|
| 1.000             | 0.053                  | 0.0530                       | 0.053                       |
| 2.035             | 0.107                  | 0.0526                       | 0.218                       |
| 2.989             | 0.160                  | 0.0535                       | 0.478                       |
| 4.010             | 0.216                  | 0.0539                       | 0.866                       |
| 5.012             | 0.272                  | 0.0543                       | 1.363                       |
| 6.005             | 0.326                  | 0.0543                       | 1.958                       |
| 7.020             | 0.384                  | 0.0547                       | 2.696                       |