

TECH NOTE

LRS-9424B Current Source and Monitor Photodiode Measurement Stability

OVERVIEW

This technical note presents typical 1000 hour test results of laser current source stability and monitor photodiode measurement stability of an LRS-9424B Laser Diode Reliability and Burn-In Test System.

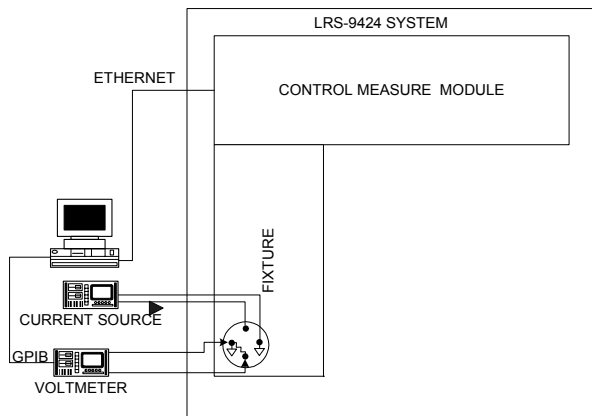

FIGURE 1 – Measurement Setup Diagram

MEASUREMENT SETUP

The measurement setup is shown in Figure 1. A low temperature coefficient 10 Ω resistor was loaded into a standard LRS9424B fixture as a dummy load. A precision current source was connected to the monitor photodiode pins and set to inject 1mA into the monitor diode measurement circuit. The system's ReliaTest system control software was configured to run 25mA in constant current mode for 1000 hours. ReliaTest recorded the monitor photodiode current every 30 minutes with a 30 minute average. Measurements of the voltage across the 10 Ω resistor were taken with an external voltmeter once a minute. The measurement data from the voltmeter was post processed to provide 30 minute averaged data.

RESULTS

The results from this test are shown in Figure 2. It can be seen from these results that the monitor photodiode measurement drift was lower than the measurement resolution of the system during the 1000 hour test. Laser diode current drift was less than 0.02% of full scale during the 1000 hour test. This low level of drift is five times better than the specification of $\pm 0.1\%$ of full scale. It should be noted that this error was primarily due to an ambient temperature change that was outside of the system operating temperature range of $23 \pm 5^\circ\text{C}$.

Finally, it should also be noted that voltage and temperature measurement data were lost during the middle of the test. This loss of data was due to the external measurement equipment losing power. In normal system tests the LRS-9424B system handles power outages in an elegant fashion with tests restarting once power is restored.

TECH NOTE

CMM Laser Current Stability and Monitor Photodiode Measurement Stability

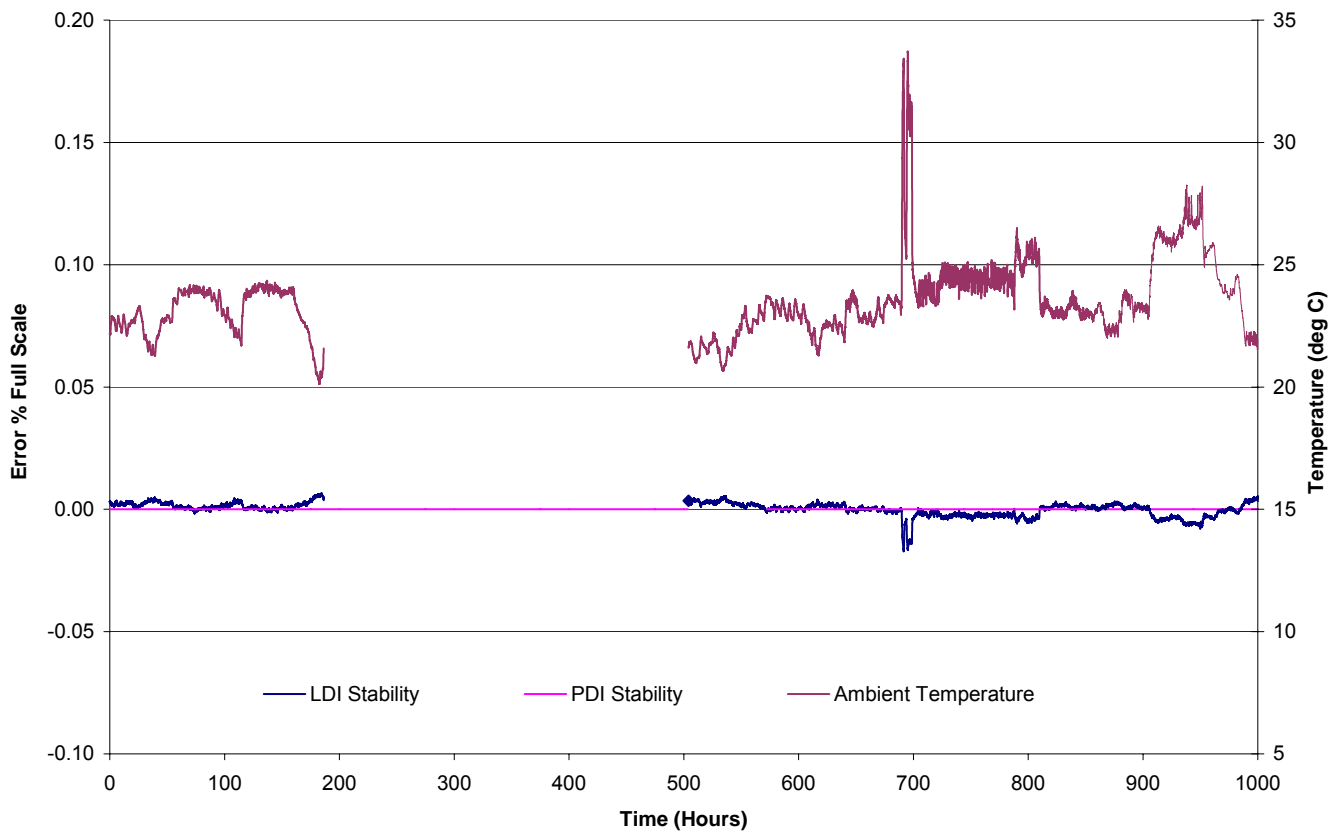

FIGURE 2 - LRS-9424B Laser Current Source and Monitor Photodiode Measurement Stability