

User's Guide

Laser Diode Mount
LDM-49800

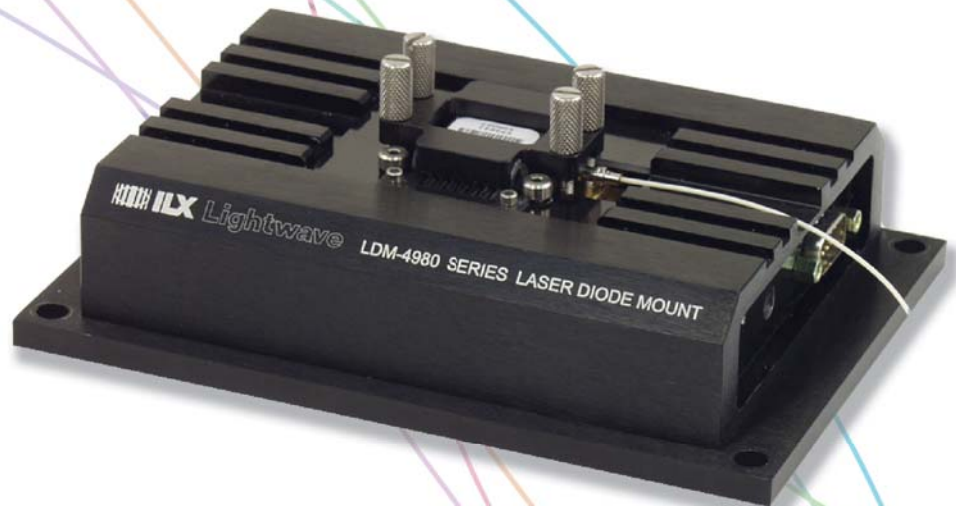

 **ILX Lightwave**
Photonic Test and Measurement

ILX Lightwave Corporation • P. O. Box 6310 • Bozeman, MT, U.S.A. 59771 • U.S. & Canada: **1-800-459-9459** • International Inquiries: 406-556-2481 • Fax 406-586-9405

ilx.custhelp.com • www.ilxlightwave.com



TABLE OF CONTENTS



Table of Contents i

List of Figures iii

List of Tables v

Safety and Warranty Information vii

 Safety Information and the Manualvii

 General Safety Considerationsvii

Safety Symbols viii

 Safety Marking Symbols viii

Warranty ix

 Comments, Suggestions, and Problems x

Chapter 1 Introduction

Product Overview 1

Specifications 3

Chapter 2 Operation

Electrical Connections 5

 LDM-49800 Wiring Instructions 5

 LDM-49800 Laser Current Control 6

 LDM-49800 Case Temperature Measurement 6

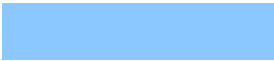

TABLE OF CONTENTS

LDM-49800T Case Temperature Control	6
Electrical Precautions	11
ILX Lightwave Current Source Interlock Feature	11
Laser Diode Mounting	12
Butterfly Laser Diode Mounting	12
2-Pin Laser Diode Mounting	13
Current Sources and Current Measurements	15
Temperature Control	16
Thermoelectric Temperature Control	16
Water Cooling	16
Disassembly	17
LDM-49840 Pin Guide Replacement	17
Bottom Plate Removal	17

Chapter 3 Maintenance

Chapter 4 Safety



LIST OF FIGURES



Figure 1.1 LDM-49800 Exploded View 2

Figure 2.1 Laser Current Connector, Female 6

Figure 2.2 Case Temperature Measurement Connector, Male 6

Figure 2.3 Case Temperature Control Connector, Male 7

Figure 2.4 Bottom View of the LDM-49840 8

Figure 2.5 LDM-49840 Configuration Label 9

Figure 2.6 LDM-49840 Laser Diode Mounting 13

Figure 2.7 LDM-49860 Laser Diode Insertion 14

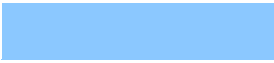

LIST OF FIGURES



LIST OF TABLES



Table 2.1	Laser Diode Pin Configuration with Internal TEC	9
Table 2.2	Butterfly Package Wiring Configuration	10
Table 2.3	LDM-49860 Pin Block Device Compatibility	13

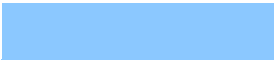

LIST OF TABLES

SAFETY AND WARRANTY INFORMATION

The Safety and Warranty Information section provides details about cautionary symbols used in the manual, safety markings used on the instrument, and information about the Warranty including Customer Service contact information.

Safety Information and the Manual

Throughout this manual, you will see the words *Caution* and *Warning* indicating potentially dangerous or hazardous situations which, if not avoided, could result in death, serious or minor injury, or damage to the product. Specifically:

CAUTION

Caution indicates a potentially hazardous situation which can result in minor or moderate injury or damage to the product or equipment.

WARNING

Warning indicates a potentially dangerous situation which can result in serious injury or death.

WARNING

Visible and/or invisible laser radiation. Avoid direct exposure to the beam.

General Safety Considerations

If any of the following conditions exist, or are even suspected, do not use the instrument until safe operation can be verified by trained service personnel:

- Visible damage
- Severe transport stress
- Prolonged storage under adverse conditions
- Failure to perform intended measurements or functions

If necessary, return the instrument to ILX Lightwave, or authorized local ILX Lightwave distributor, for service or repair to ensure that safety features are maintained (see the contact information on page x).

All instruments returned to ILX Lightwave are required to have a Return Authorization Number assigned by an official representative of ILX Lightwave Corporation. See Returning an Instrument on page ix for more information.

SAFETY SYMBOLS







This section describes the safety symbols and classifications.

Technical specifications including electrical ratings and weight are included within the manual. See the Table of Contents to locate the specifications and other product information. The following classifications are standard across all ILX Lightwave products:

- Indoor use only
- Ordinary Protection: This product is NOT protected against the harmful ingress of moisture.
- Class I Equipment (grounded type)
- Pollution Degree II
- Installation (overvoltage) Category II for transient overvoltages
- Maximum Relative Humidity: <80% RH, non-condensing
- Operating temperature range of 0 °C to 40 °C
- Storage and transportation temperature of -40 °C to 70 °C
- Maximum altitude: 3000 m (9843 ft)
- This equipment is suitable for continuous operation.

Safety Marking Symbols

This section provides a description of the safety marking symbols that appear on the instrument. These symbols provide information about potentially dangerous situations which can result in death, injury, or damage to the instrument and other components.

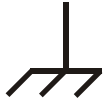
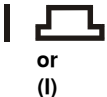
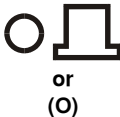
 <p>Caution, refer to manual</p>	 <p>Earth ground Terminal</p>	 <p>Alternating current</p>	 <p>Visible and/or invisible laser radiation</p>
 <p>Caution, risk of electric shock</p>	 <p>Protective Conductor Terminal</p>	 <p>Caution, hot surface</p>	 <p>Frame or chassis Terminal</p>
 <p>On: In position of a bistable push control. The slash (/) only denotes that mains are on.</p>		 <p>Off: Out position of a bistable push control. The circle (O) only denotes that mains are off.</p>	

WARRANTY

ILX LIGHTWAVE CORPORATION warrants this instrument to be free from defects in material and workmanship for a period of one year from date of shipment. During the warranty period, ILX will repair or replace the unit, at our option, without charge.

Limitations

This warranty does not apply to fuses, lamps, defects caused by abuse, modifications, or to use of the product for which it was not intended.

This warranty is in lieu of all other warranties, expressed or implied, including any implied warranty of merchantability or fitness for any particular purpose. ILX Lightwave Corporation shall not be liable for any incidental, special, or consequential damages.

If a problem occurs, please contact ILX Lightwave Corporation with the instrument's serial number, and thoroughly describe the nature of the problem.

Returning an Instrument

If an instrument is to be shipped to ILX Lightwave for repair or service, be sure to:

- 1 Obtain a Return Authorization number (RA) from ILX Customer Service.
- 2 Attach a tag to the instrument identifying the owner and indicating the required service or repair. Include the instrument serial number from the rear panel of the instrument.
- 3 Attach the anti-static protective caps that were shipped with the instrument and place the instrument in a protective anti-static bag.
- 4 Place the instrument in the original packing container with at least 3 inches (7.5 cm) of compressible packaging material. **Shipping damage is not covered by this warranty.**
- 5 Secure the packing box with fiber reinforced strapping tape or metal bands.
- 6 Send the instrument, transportation pre-paid, to ILX Lightwave. Clearly write the return authorization number on the outside of the box and on the shipping paperwork. ILX Lightwave recommends you insure the shipment.

If the original shipping container is not available, place your instrument in a container with at least 3 inches (7.5 cm) of compressible packaging material on all sides.

Repairs are made and the instrument returned transportation pre-paid. Repairs are warranted for the remainder of the original warranty or for 90 days, whichever is greater.

Claims for Shipping Damage

When you receive the instrument, inspect it immediately for any damage or shortages on the packing list. If the instrument is damaged, file a claim with the carrier. The factory will supply you with a quotation for estimated costs of repair. You must negotiate and settle with the carrier for the amount of damage.

Comments, Suggestions, and Problems

To ensure that you get the most out of your ILX Lightwave product, we ask that you direct any product operation or service related questions or comments to ILX Lightwave Customer Support. You may contact us in whatever way is most convenient.

In the United States:

Phone (800) 459-9459 or (406) 586-1244

Fax (406) 586-9405

Online: <http://ilx.custhelp.com>

Email: support@ilxlightwave.com

Or mail to:

ILX Lightwave Corporation
P. O. Box 6310
Bozeman, Montana, U.S.A 59771
www.ilxlightwave.com

In Europe:

Optical Test and Calibration Ltd.
Listerhills Science Park
Bradford, BD7 1HR United Kingdom
Phone: (44) 1274 393857
Fax: (44) 1274 393336
Online: www.otc.co.uk
Email: sales@otc.co.uk

In Japan:

Kyosai Technos
424, Shimo-Ongata-Machi
Hachioji-Shi
Tokyo, 192-0154 Japan
Phone: (81) 426 521 388
Fax: (81) 426 513 270

In China:

ETSC Technologies Co.
9/F Building 1
SBI Street
Dongxin Road
East Lake High-Tech Development Zone
Wuhan, Hubei, 430074 PRC China
Phone: (86) 27 8717 0152; (86) 27 8741 2681; (86) 27 8780 7925
Fax: (86) 27 8780 7133
Online: www.etsc-tech.com
Email: sales@etsc-tech.com

In China:

Kyosai Technos
3F Bldg G, No.21 Changjiang Road, Wuxi
National Hi-Tech Development Zone
Jiangsu, P.R. China
Phone: (86) 510 522 1707
Fax: (86) 510 522 1679
Email: ilx-service-china@kyosaitec.co.jp

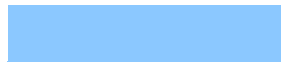

When you contact us, please have the following information:

Model Number: _____

Serial Number: _____

End-user Name: _____

Company: _____

Phone: _____

Fax: _____

Description of what is connected to the ILX Lightwave instrument:

Description of the problem:

If ILX Lightwave determines that a return to the factory is necessary, you are issued a Return Authorization (RA) number. Please mark this number on the outside of the shipping box.

You or your shipping service are responsible for any shipping damage when returning the instrument to ILX Lightwave; ILX recommends you insure the shipment. If the original shipping container is not available, place your instrument in a container with at least 3 inches (7.5 cm) of compressible packaging material on all sides.

We look forward to serving you even better in the future!

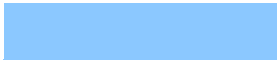

WARRANTY

Laser current and temperature control is provided through connectors on the LDM-49800 series which allows direct interfacing to most ILX Lightwave current sources and temperature controllers through interconnect cabling. Current source and temperature controller specific interconnect cables are available. This feature gives you the flexibility to select the proper current source or temperature controller for your particular application.

The LDM-49800 series consists of a black anodized housing, laser mounting block and clamp, water cooled heat sink, and base for mounting to an optical table or positioner. The LDM-49840 also includes a PCB for signal routing to the laser and can be ordered with a specific clamp for 6-pin, 8-pin or 14-pin modules. The housing includes a grounding receptacle for a wrist strap.

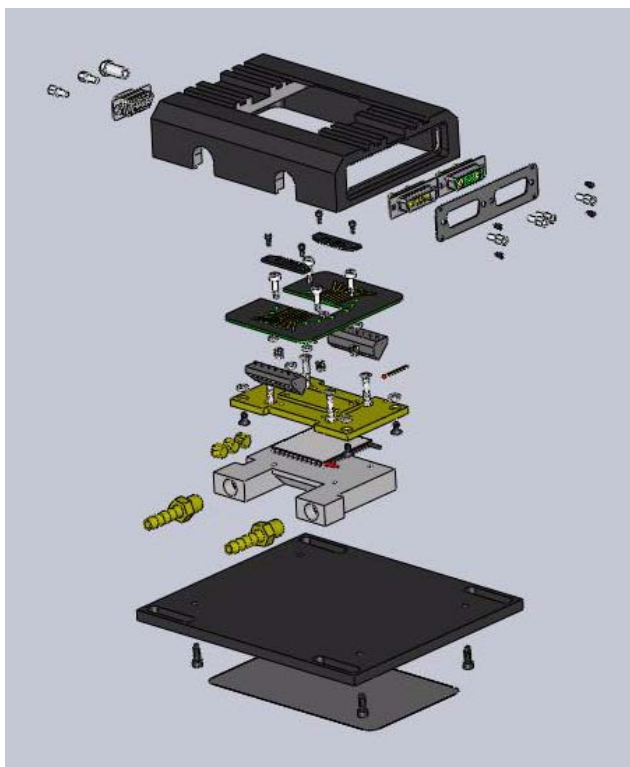

Figure 1.1 LDM-49800 Exploded View

Specifications

Laser Packages	2-pin modules and 6-pin, 8-pin, 14-pin fiber-coupled butterfly packaged
49840 Laser Dimensions	
6-pin	19 mm x 15 mm
8-pin	12.7 mm x 21.84 mm
14-pin	12.7 mm x 30 mm
49840 Maximum Pin Width	1.25 mm
49860 2-pin Module Compatability	JDS Uniphase, Bookham, EM4, Lumics
Maximum Laser Current (49840)	12 A
Maximum Laser Current (49860)	20 A
Maximum Thermal Load (49840)	60 W
Maximum Thermal Load (49860)	40 W
Laser Clamping	#6-32 UNC, thumbscrew
Laser to Hotplate Contact Thermal Resistance ¹	$\leq 0.10^{\circ}\text{C}\cdot\text{in}^2\cdot\text{W}^{-1}$
Repeatability	$\pm 0.01^{\circ}\text{C}\cdot\text{in}^2\cdot\text{W}^{-1}$
Connectors	
Laser Diode Current	Hybrid D-sub, male
Internal Temperature Control (49840/49840T only)	9-pin D-sub, female
Case Temperature Control	Hybrid D-sub, male
Internal Thermistor (without case temperature control)	15-pin D-sub, male
Ground	Banana jack, female
Water Connectors	1/8" NPT to 1/4" nipple, barbed
Water Pressure Drop	5 psi at 1.0 GPM
Temperature Sensor	10 k Ω NTC thermistor
Cold Plate Thermal Resistance ²	0.25 $^{\circ}\text{C}/\text{W}$ @ 1.0 GPM
49840T Case Control	Solid State, Thermoelectric
Thermal Load	60W
Temperature Control Range ³	15 $^{\circ}\text{C}$ to 85 $^{\circ}\text{C}$
TE Module ⁴	
I_{max}	14.6 A
V_{max}	15.4 V

49860T Case Control	Solid State, Thermoelectric
Thermal Load	40W
Temperature Control Range ³	15°C to 85°C
TE Module ⁴	
I_{max}	8.5 A
V_{max}	15.4 V
General	
Size (HxWxD)	31.8 mm x 102 mm x 140 mm
Weight	2.1 lbs. (0.95 kg)
Regulatory Compliance	RoHS

- 1 Clamp screws tightened to 2 in*lbs torque. To find thermal resistance in °C/W, multiply by surface area of laser diode package base.
- 2 49840 and 49860 only, defined as (hotplate temperature - inlet water temperature) / thermal load.
- 3 Control range at maximum thermal load. Mount can control down to 0°C at lower heat loads. See tech note "Thermal Range of the LDM-49800". Assumes 20°C water temperature and and 1.0 GPM (3.79 liter/min) flow rate . Lower control temperatures can be achieved with lower water temperatures for any given heat load.
- 3 Module ratings based on a single TE module at 25°C operating temperature. For optimizing TEC current limits on a temperature controller, see application note #14: "Optimizing TEC Drive Current".

Our goal is to make the best laser diode instrumentation available anywhere. To achieve this, we need your ideas and comments on ways we can improve our products. We invite you to contact us at any time with your suggestions.



This chapter describes the electrical configuration and mounting of laser diodes.

Electrical Connections

CAUTION

Laser diodes are extremely susceptible to damage caused by electrostatic discharge and surge currents. To avoid early failure or damage to the device, workers and work benches must be grounded at all times when handling or working with laser diodes.

For more information on laser diode protection strategies, refer to Application Note #3, "Protecting Your Laser Diode." This document is available on our website: <http://www.ilxlightwave.com>.

LDM-49800 Wiring Instructions

The LDM-49800 is equipped with connectors for laser current and external case temperature measurement. The LDM-49840 also includes a connector for laser diode internal TEC control. The LDM-49800T has in place of the mount temperature connector another that includes pins for case temperature control. Configurable pin headers, accessible from the bottom side of the mount allow the LDM-49840 mount to be configured for any laser module pin-out. The LDM-49860 2-pin mount is configured from the factory and requires no modifications prior to use. This section describes connecting a current source and temperature controller to the mount, and configuration of the mount for a particular laser diode.

LDM-49800 Laser Current Control

All LDM-49800 mounts use a 7W2 female hybrid D-sub connector for laser current connections. These include laser anode and cathode, internal photodiode anode and cathode, and voltage sense. The pin out for the laser current control connector is given in Figure 2.1.

- Pin A1: Laser Cathode (-)
- Pin A2: Laser Anode (+)
- Pin 1: Chassis Ground
- Pin 2: PD Cathode (-)
- Pin 3: PD Anode (+)
- Pin 4: Voltage Sense (+)
- Pin 5: Voltage Sense (-)

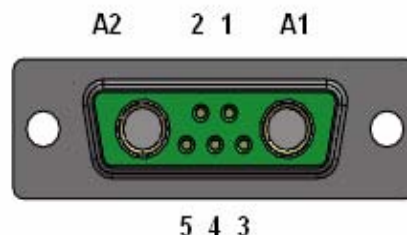

Figure 2.1 Laser Current Connector, Female

LDM-49800 Case Temperature Measurement

Non-case temperature controlled mounts feature a 15-pin D-sub connector that includes 2 pins for external case temperature measurement. This feature can be used for external monitoring of hot plate temperature or for temperature sense of an external chiller. The pin out for the case temperature measurement connector is shown in Figure 2.2.

- Pins 1-3: No connection
- Pin 7: Thermistor +
- Pin 8: Thermistor -
- Pins 6-15: No connection

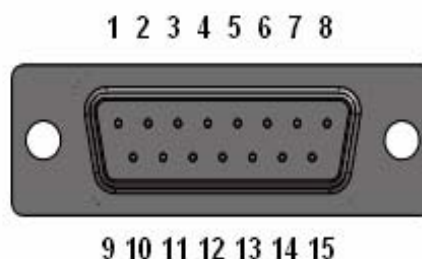

Figure 2.2 Case Temperature Measurement Connector, Male

LDM-49800T Case Temperature Control

An external case temperature control module with a built-in thermoelectric module is also available. External case temperature control allows for control of package temperature, resulting in simultaneous and independent temperature control of both laser die temperature and package temperature. A D-sub 7W2 connector on the mount facilitates connecting a temperature controller such as an ILX LDT-

5980 to the mount. Interconnect cables are also available. The pin out for the case temperature control connector is shown in Figure 2.3.

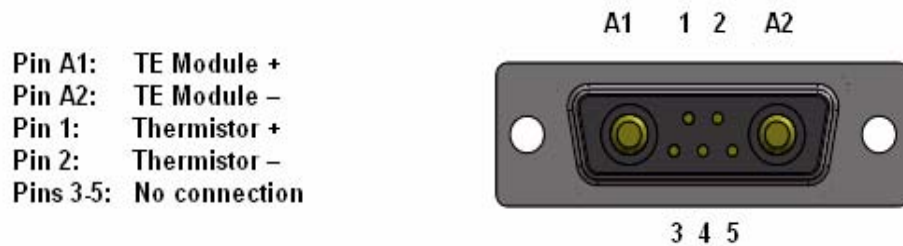

Figure 2.3 Case Temperature Control Connector, Male

A drawing of the inside of the LDM-49840 is shown in Figure 2.4. Remove the base of the mount with a 7/64" allen head wrench or equivalent driver. The configuration terminal blocks are located on the left and right hand side and are soldered to the bottom side of the printed circuit board. The numbers next to the headers designate the laser pin number. The connectors for laser current, internal TE, and case temperature control are located on the ends of the mount above and below the cold plate.

Color coded wires are soldered to the connectors and un-terminated at the other end for insertion into the terminal blocks. The pin-outs for the connectors and the corresponding wire color are shown on the mount baseplate. An erasable label in the center of the baseplate is available for recording the pin assignments of the mount after it is configured for the laser.

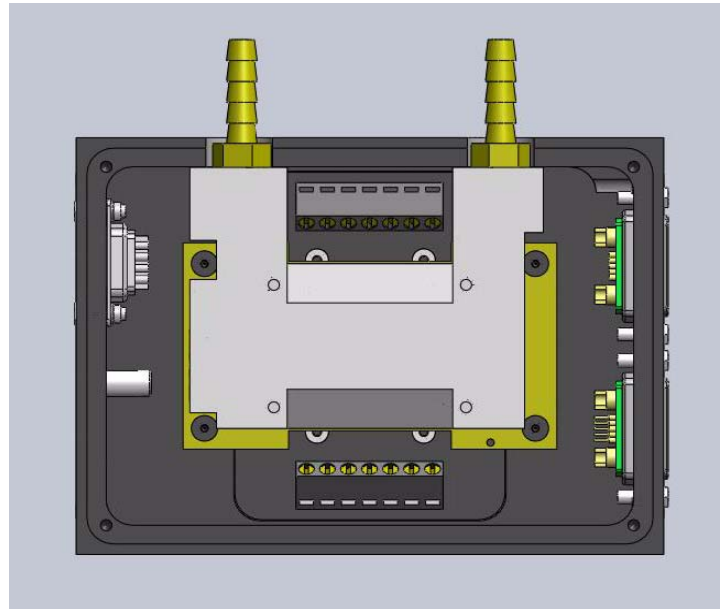

Figure 2.4 Bottom View of the LDM-49840

The mount is configured for your laser diode by connecting the color coded wires from the laser and TE connectors to the corresponding pin on the configurable headers. Insert the wires into the header and tighten the clamping screw. The connector pin designations and wire color codes are shown in Figure 2.5.

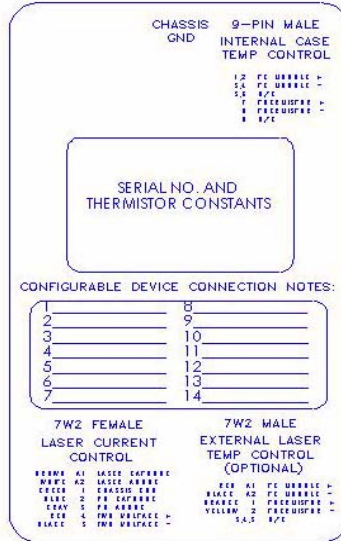

Figure 2.5 LDM-49840 Configuration Label

An example for a laser diode with internal TEC is shown in Table 2.1.

Pin #	Description	Pin #	Description
1	Peltier Cooler (+)	8	Not Connected
2	Thermistor	9	Laser Cathode (-)
3	Monitor Anode (-)	10	Laser Anode (+)
4	Monitor Cathode (+)	11	Laser Cathode (-)
5	Thermistor	12	Not Connected
6	Monitor Cathode	13	Case Ground
7	Monitor Anode	14	Peltier Cooler (-)

Table 2.1 Laser Diode Pin Configuration with Internal TEC

Note: Information Courtesy of Bookham Technology

To configure the mount for this particular laser diode, follow the instructions below:

- 1 Starting with pin 1, Peltier cooler (+), you would connect the red wire from the Internal Laser Temp Control connector to pin 1 of the configurable header.
- 2 Next, pin 2 of the laser is the thermistor, connect the orange wire from the Internal Laser Temp Control connector to pin 2 of the configurable header.
- 3 For pin 3, monitor anode, connect the gray wire from the Laser Current Control connector to pin 3 of the configurable header.
- 4 For pin 4, monitor cathode, connect the blue wire from the Laser Current Control connector to pin 4 of the configurable header.
- 5 For pin 5, thermistor, connect the yellow wire from the Internal Laser Temp Control connector to pin 5 of the configurable header.
- 6 There are no connections for pin 6, 7, 8 and 9.
- 7 For pin 10, laser anode, connect the white wire from the Laser Current Control connector to pin 10 of the configurable header.
- 8 For pin 11, laser cathode, connect the brown wire from the Laser Current Control connector to pin 11 of the configurable header.
- 9 There are no connections for pin 12 and 13.
- 10 To finish the wiring, for pin 14, peltier cooler (-), connect the black wire from the Internal Laser Temp Control connector to pin 14 of the configurable header.

The configuration information with connector designation with corresponding wire color is summarized in Table 2.2.

Pin	Designation	Wire Color	Mount Connector	Pin	Designation	Wire Color	Mount Connector
1	TE Cooler (+)	Red	Internal laser temp control	8	NC	-----	
2	Thermistor	Orange	Internal laser temp control	9	NC	-----	
3	Monitor Anode (-)	Gray	Laser current control	10	Laser Anode (+)	White	Laser current control
4	Monitor Cathode (+)	Blue	Laser current control	11	Laser Cathode (-)	Brown	Laser current control
5	Thermistor	Yellow	Internal laser temp control	12	NC	-----	
6	NC	-----		13	NC	-----	
7	NC	-----		14	TE Cooler (-)	Black	Internal laser temp control

Table 2.2 Butterfly Package Wiring Configuration

The mount is now configured for this laser module. It is always a good idea to double check your work before powering up the laser diode to make sure the connections are correct.

Please note that some connections on the laser package may have multiple pins. These pins are usually a common ground and one or two other functions. Do not be concerned if one or more of these common pins are left unconnected. Simply verify that each laser pin is correctly connected to the corresponding 9-pin connector pin through the configurable header. Once all appropriate connections have been made and verified, attach the baseplate.

Electrical Precautions

CAUTION

It is extremely important that you verify that the wiring of the configurable headers is correct for your laser type (pinout). Incorrect wiring of these headers may result in destruction or damage of the laser device.

The LDM-49800 mount is compatible with most current sources and temperature controllers manufactured by ILX Lightwave. If you are using any other laser driver, use extreme caution when connecting cables from the mount to the driver. Check the laser driver/temperature controller pin-out for compatibility with this mount before connecting the instruments.

ILX Lightwave Current Source Interlock Feature

In compliance with Federal CDRH requirements, ILX Lightwave current sources employ a system interlock feature. The interlock connections are available at pins 1 and 2 on all current sources except the LDX-36000 Series High Power Drivers. On the LDX-36000 Series, there are two separate interlocks accessible from a terminal block on the rear panel. The interlock pins must be shorted together before current can flow from the source. ILX Lightwave's Model CC-305H and CC-306HT interconnect cables contain a jumper between these two pins; therefore, no special action is necessary if this cable is used. If a user-supplied cable is used with an ILX Lightwave current source, the interlock pins will have to be shorted in the cable.

Refer to the laser diode drive instrument manual for more information on the interlock feature.

CAUTION

When connecting high current wires, it is extremely important to ensure good connections by maximizing contact area and tight connections.

Laser Diode Mounting

CAUTION

Laser diodes are extremely susceptible to damage caused by electrostatic discharge and surge currents. To avoid early failure or damage to the device, workers and work benches must be grounded at all times when handling or working with laser diodes. Refer to ILX Application Note #3, "Protecting Your Laser Diode," for more information.

The LDM-49800 mount is equipped with a grounding jack on the side, which is electrically connected to the mount chassis. We strongly recommend that you electrically ground yourself with a wrist strap so that you are assured of being at the same potential as the mount chassis.

Prior to inserting the laser, connect the current source to the mount. At this time, also connect the temperature controller if the laser is equipped with an internal temperature control module. Finally, connect the temperature controller for the external case temperature control if the LDM-49800T option was ordered.

When the mount electrical connections and laser driver are correctly configured, the laser cathode and anode connections are shorted through an ILX Lightwave current source when the current drive is switched off. This prevents damage to the laser from electrostatic discharge and supports other laser safety features of all ILX Lightwave laser diode drivers.

Butterfly Laser Diode Mounting

The LDM-49840 allows clamping and electrical connection to 6-pin, 8-pin, and 14-pin butterfly laser diodes. The mount accepts any of these packages with pin widths up to 1.25 mm. Pin guides for 6-pin, 8-pin, or 14-pin modules are exclusive to the module pin number and come assembled to the mount. To replace the pin guides to accommodate other laser configurations, remove the two screws per pin guide with a 5/64" allen head wrench or equivalent driver. Replace the pin guides with the appropriate ones.

Place the laser module on the hot plate located beneath the printed circuit board while aligning the module pins with the grooves in the pin guides. Align the fiber in the same direction as the arrow silkscreened on the top surface of the housing. Once placed on the hot plate, place the clamp over the top of the laser module letting the bottom pads contact the module base. Rubber tubes on the sides of the clamp contact the module pins and push down on them against the spring-loaded circuit board to make the electrical connection between the pins and the printed circuit board. Insert the four screws into the clamp and tighten to 2 in*lbs torque using an alternating pattern to ensure even pressure on the module and pins. Only use the four 6-32 x 3/5" thumbscrews provided with the mount. Longer

screws may damage the TECs. The clamp pushes on the laser module base for a good thermal connection between it and the mount.

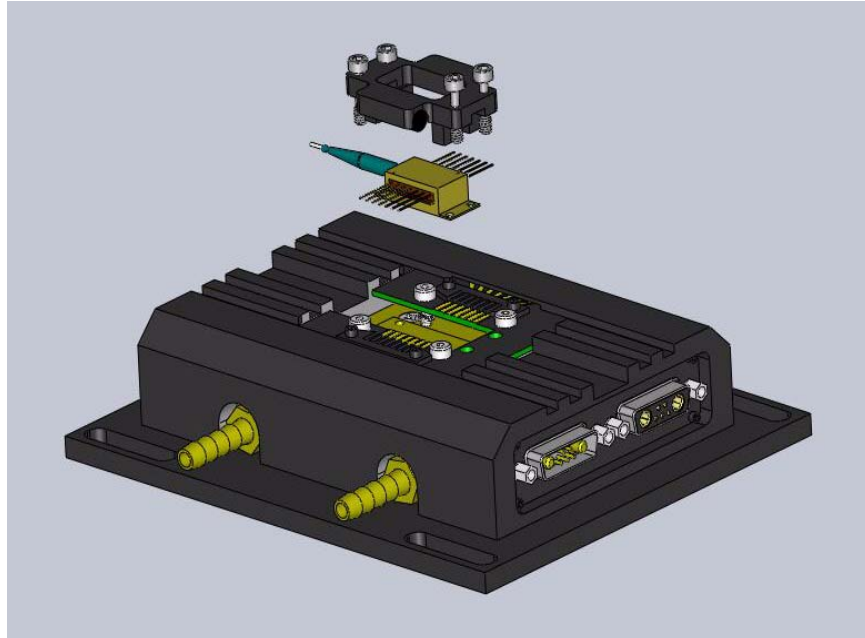

Figure 2.6 LDM-49840 Laser Diode Mounting

2-Pin Laser Diode Mounting

The LDM-49860 mount comes with one of three pin blocks installed. Table 2.3 shows laser diode compatibility with the different pin blocks.

Manufacturer	Laser Diode Model	49860 Pin Block
JDSU	L3	LDM-4986001
JDSU	L4	LDM-4986001
Lumics	LU0xx	LDM-4986003
Bookham	BMU7	LDM-4986002
EM4	EM298-303	LDM-4986002

Table 2.3 LDM-49860 Pin Block Device Compatibility

With the correct pin block installed, place the laser diode on the mount hot plate and carefully slide the pins into the pin block receptacles until they bottom out. The fiber should extend from the mount in the direction of the silkscreened white arrow. Place the clamp with thumb screws on top of the laser and start each screw into the threaded holes on the hot plate. Use a finger to hold the clamp body flush and level with the top of the device as you thread each screw in until it just contacts the clamp. See figure 2.4. Once all four screws are touching the clamp, make sure it is level and then tighten the screws to 2 in*lbs torque using an alternating pattern. Only use the four 6-32 x 3/4" thumbscrews provided with the mount. Longer screws may damage the TECs.

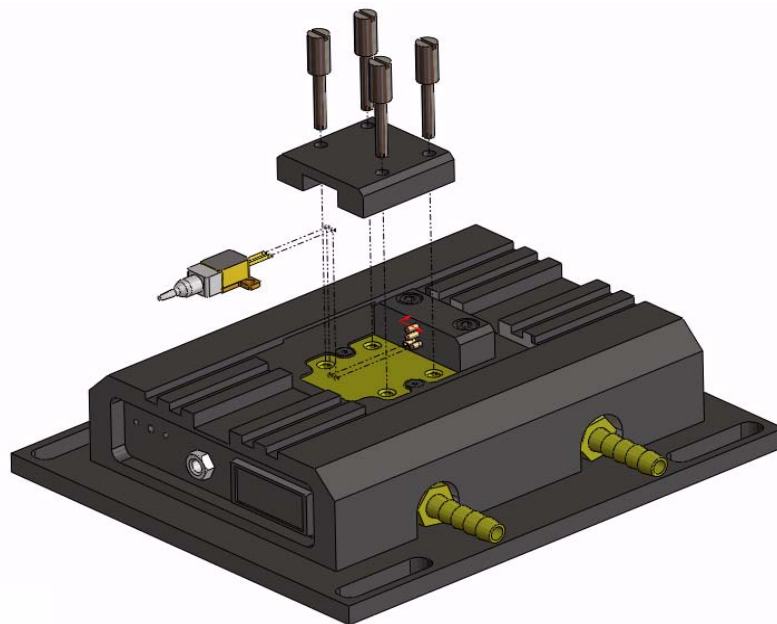

Figure 2.7 LDM-49860 Laser Diode Insertion

Current Sources and Current Measurements

CAUTION

Do not exceed the specified current settings of the laser. Excessive drive current may cause laser failure.

Operate the LDM-49800 Laser Diode Mount using ILX Lightwave current sources or temperature controllers. Operation with other current sources or temperature controllers is also possible, provided that the correct wiring is observed (refer to Chapter 2, LDM-49800 Wiring Instructions).

Do not exceed the specified maximum drive current of the laser. If you are using an ILX Lightwave current source, or any other current source which has an adjustable limit setting, be sure to set the current limit to a safe level for your laser. If it is necessary to measure the current of your laser during operation, follow these steps:

- 1 Never connect an ammeter in series with the laser circuit.
- 2 Place a known resistance (0.1 ohm) in series with the laser diode circuit, then measure the voltage across the resistor. Calculate the current by using Ohm's Law, $I = E/R$. Keep the resistance low enough that you don't exceed the compliance voltage of the laser driver.
- 3 Never turn the voltmeter on or off or change the voltage measurement range while current is flowing to the laser. These actions could result in failure of your laser diode.

Temperature Control

Thermoelectric Temperature Control

The operating characteristics of diode lasers vary considerably with temperature. Emission wavelength, threshold current and operating lifetime are all strong functions of device temperature. The operating lifetime drops by a factor of two for every 25°C rise in operating temperature. Thermoelectric (Peltier) devices provide a simple, reliable solution to precise temperature control in many applications of optoelectronic devices. These solid-state devices can heat or cool thermal loads to more than 60°C from ambient and achieve temperature stabilities of better than 0.001°C. Active temperature control of the LDM-49800 is accomplished with a thermoelectric module and a temperature measurement element using a thermistor for real-time feedback to a thermoelectric temperature controller such as an ILX Lightwave LDT-5980. The actual temperature is measured by the temperature sensor under the top plate near the front of the mount. This temperature is then compared to a setpoint temperature, to produce an error signal proportional to the difference between setpoint and actual temperature. The temperature controller outputs a proportional bi-directional current to the thermoelectric modules depending on the direction of the error.

CAUTION

Thermal resistance, measured in °C/W, between the laser package and the laser plate results in a temperature difference between the laser plate and laser diode. The laser plate is gold plated for better thermal conductivity.

Caution must be used when placing a laser diode in the mount and removing it not to scratch the surface between the laser and the laser plate. Scratches and contamination of the surface will degrade the thermal performance of the mount resulting in an increase of the thermal resistance between the laser and laser plate.

Water Cooling

The LDM-49800 contains a forced convection heat sink for use with chilled water. Water cooling allows lowering the operating temperature by providing higher heat dissipation than air cooling. The LDM-49800 series mounts come with 1/4" barbed brass inlet and outlet fittings installed (for use with 1/4" ID tubing). Attach the water supply and return lines to the mount. Worm-drive hose clamps are recommended. The cold plate uses symmetrical geometry so direction of flow does not affect performance. The LDM-49800 is optimized for flow rates between 0.5 and 1.0 GPM (1.9 and 3.8 L/min). The rated temperature range and power range is based on 20°C water. Lower flow rates and higher water temperatures will decrease cooling capacity, while higher flow rates and lower water temperatures will increase cooling capacity.

Disassembly

LDM-49840 Pin Guide Replacement

Two pin guides are attached to the printed circuit board on the top of the mount. These can be removed and replaced with pin guides for 6-pin, 8-pin, and 14-pin laser modules. To remove the pin guides, remove two #2-56 x 3/16" screws per pin guide with a 5/64" allen head wrench or equivalent driver. Replace the pin guide by locating the appropriate pin guide to the circuit board, insert the two #2-56 screws and tighten them.

Bottom Plate Removal

The configuration terminal blocks can be easily accessed by removing the bottom plate of the LDM-49800. This is accomplished by removed four #6-32 x 3/8" screws with a 7/64" allen head wrench or equivalent driver.

No further disassembly of the mount should be performed.

MAINTENANCE



No maintenance procedures are required for the LDM-49800 other than an occasional cleaning, as needed, to remove any accumulated dust or dirt from the external surfaces.

When the mount is not in use for prolonged periods, it is recommended to insert plastic anti-static covers over the connectors. Store the mount with the grounded laser cover installed.

SAFETY



Laser diodes used with the LDM-49800 Series Laser Diode Mount may emit infrared radiation, which is invisible to the human eye. Extreme care must be taken to prevent the beam from being viewed either directly or through external optics or mirrors. Remove rings, jewelry, and other reflective materials when working with lasers.

 **CAUTION**

Viewing of emissions from the fiber may cause eye damage. Use of protective goggles is recommended when operating these lasers.

 **CAUTION**

Use of controls or adjustments or performance of procedures other than those specified herein may result in hazardous radiation exposure.

This product conforms to all applicable DHHS regulations 21 CFR Subchapter J, at the date of manufacture.

